

K7LED Relay

Volume 46, Issue 3

Mike & Key Amateur Radio Club – Seattle

March 2018

It's March!

From David Smith KB7PSN President

It's March already – where has the year gone?! We survived the Club's Flea Market / Swap Meet down at the Puyallup Fairgrounds. This is one of the bigger events like this in the area and is well attended by the amateur radio community. The show is one of the Club's major fund raisers for the year and helps us to meet the budget line items that were approved back in December of last year.

The event also provides an opportunity to catch up on what the ham community has been up to since last year. Also, after the event is done and everything is cleaned up, volunteers meet at the [Main Garden Restaurant](#) to celebrate a job well done before going home.

At the March Club Meeting, we will be holding elections for the 2018 Officers on the Board. All members who have been nominated are to be voted on during the regular business meeting. There are 11 board members – President, Vice President, Secretary, Treasurer, Activity Manager, Radio Officer, and five Trustees. The Radio Officer is appointed by the Board. Trustees are nominated for a two-year term, with Trustee #1, #3, and #5 voted on in odd years. And Trustee #2 and #4 voted on in even years; thus, for 2018, there will be two Trustees being voted on. Positions are described within the [Club Bylaws](#) (March 2015).

Shortly after the March Club Meeting, we will be filing the long IRS long form 1023 to apply for 501(c)3 status. This application process will take a while to approve. As part of this process, The Board has requested an update of the [About Us](#) web page to help identify what The Club does for the amateur radio community.

Looking forward to seeing you at the events this month.



Celebrate our March Members

By Jim Kiniry KE7JIM, Treasurer

As of March 2018, these folks have been Mike & Key members for the number of years stated. Congratulations to all of you, and thank you for your participation and service.

Happy Anniversary this month!

Each of you makes us who we are.

| Name | Callsign | NumYears |
|-------------------------|---------------|-----------------|
| Dan Humphrey * | N7QHC | 27 Years |
| Robert Crooker * | KB7PEC | 25 Years |
| Kathy Martin | KB7QMO | 24 Years |
| Jack McCall | W7TMW | 20 Years |
| Dorothy Lowell | KB7WSO | 18 Years |
| Gail Richardson | KI4JVM | 13 Years |
| Laura Bendit | KF7ELG | 9 Years |
| Brett Traicoff * | No Call | 8 Years |
| Kirk Butler | K6GNW | 4 Years |
| Eric Skone | K7ELK | 4 Years |
| Michael Kubasti | W7MJK | 3 Years |
| Whit Worcester | KG7LNZ | 3 Years |
| Patricia Crockett | KG7WMK | 2 Years |
| Keith Johnson | KG7CNU | 2 Years |
| William Allison | K17BZ | 1 Year |
| Rich Gallaher | K7RCH | 1 Year |
| Bruce Gary | K7BGG | 1 Year |
| Mark Taylor | KD7UDE | 1 Year |





The *K7LED Relay*, published monthly, is the official newsletter of the Mike & Key Amateur Radio Club. The Mike & Key ARC is an ARRL-affiliated club dedicated to the growth and betterment of Amateur Radio. The Club meets at 10AM on the third Saturday of each month at the Salvation Army Headquarters, 720 S. Tobin Street, | in Renton (near the southeast corner of Renton Airport). Anyone interested in Amateur Radio is invited to participate in the Mike & Key ARC and its activities. Annual dues are \$12 for individuals and \$18 for families.

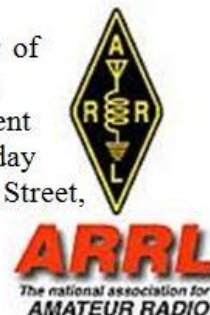

Postal Address:
P.O. Box 4234
Renton, WA 98057-4234

Web Site:
www.mikeandkey.org

Send dues to:
Mike & Key ARC
P.O. Box 4234
Renton, WA 98057-4234

K7LED Repeaters:
146.82 output / 146.22 input
(PL 103.5)Tiger Mountain

Email:
info @ mikeandkey.org

Send newsletter submissions to:
Michael Dinkelman, *Relay* Editor
n7wa @ arrl.net
253-631-3756

224.120 output / 222.520 input
(PL 103.5)Tiger Mountain

Reflector:
<http://groups.yahoo.com/groups/mkarc>

Club Contacts

| | | | | |
|-------------------------|-----------------|--------|------------------------|--------------|
| President | David Smith | KB7PSN | kb7psn @ yahoo.com | 425-235-5095 |
| Vice President | David Yarbrough | WA7DY | wa7dy@arrl.net | 425-445-2792 |
| Secretary | Phillip Pia | K7PIA | k7pia@yahoo.com | 253-307-4781 |
| Treasurer | Jim Kiniry | KE7JIM | ke7jim@outlook.com | 206-979-5717 |
| Activity Manager | Jim Monson | K7JGM | jgmonson@earthlink.net | 206-245-8485 |
| Radio Officer | Hal Goodell | N7NW | n7nw.hal @ comcast.net | 253-549-4178 |

Trustees

| | | | | |
|--------------------|--------------|--------|-----------------------------|--------------|
| No. 1 – | Steve Cook | KD7IQL | kd7iql@gmail.com | 253-245-6435 |
| No. 2 – | Steve Marth | WB7AAV | marthnet@msn.com | 206-915-2205 |
| No. 3 – CoB | Tim Kane | K7ANE | k7ane@arrl.net | 206-251-7467 |
| No. 4 – | Tom Helm | WT7S | thomas.c.helm1051@gmail.com | 206-307-6025 |
| No. 5 – | Robin Carter | WA7BRI | rjc@centurytel.net | 253-858-2008 |

Committees

| | | | | |
|-----------------------|-----------------|--------|--|--------------|
| VE Testing | Scott Robinson | AG7T | ag7t @ arrl.net | 425-788-0452 |
| Membership | Steve Marth | WB7AAV | mikeandkeymembers@gmail.com | |
| Logo | Jim Aigner | N7MU | jimaigner @ comcast.net | 253-630-2752 |
| Club Library | 'Toku' Okumura | AD7JA | ad7ja@msn.com | 206-772-2450 |
| Webmaster | Jim Etwiler | KD7BAT | kd7bat@arrl.net | 425-788-7887 |
| Public Service | Robert Grinnell | KD7WNV | kd7wnv@arrl.net | 425-398-1466 |

Mike & Key Online –The following Club resources are available:

On the Web – The Club's site at www.mikeandkey.org includes extensive information about Club activities and events, such as: VE testing, membership, past editions of the Relay and more.

Reflector – The Club's public message board offers an easy and free way to converse with Club members. To sign up, visit: <http://groups.yahoo.com/groups/mkarc> .

E-Relay – Help the Club save on printing and postage, send Email to the *Relay* Editor: n7wa @ arrl.net.

March 2018

K7LED Relay

[Around The Shack](#)

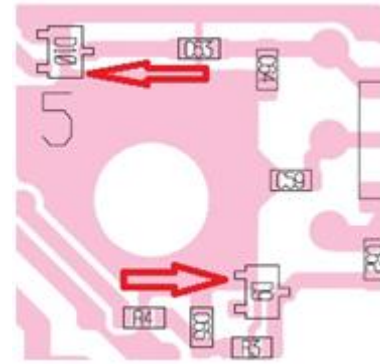
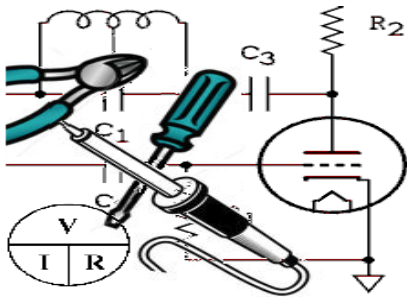

Last month, I left you with the question of “did I fix the rig?” Also, am I transmitting? Is the modulation working? How much RF power am I generating?

These were all questions that were running through my mind as I tried to figure out what was wrong with my IC-706MKIIG. That’s why I had to peek inside the cable to see what kind of RF output I was getting (See last month’s article). That tool was most helpful. I would key up into a dummy load on AM and see the power fluctuate the wattage output; 2-3-7-0-12-0-0-3-1-0-0-10.... And all I was doing was holding the PTT.

I had torn the rig apart and verified the Main board, Modulation circuits and PA were all doing what they were supposed to do. It has to be something between the PA and Antenna output.

YouTube didn’t help. Blah blah blah... replace the filter board. Yeah, right. Not for \$200.

A little more research and found a suggestion regarding the SWR sensing circuit on the filter board. This made more sense. If the unit thinks the SWR is too high, it’ll throttle back the power.

The schematic only had two suspects for the SWR sensing circuit in this investigation. D9 and D10, as seen in the schematic and board layout pics below.

I dug out the 10x jewelers eye loop and took a look at the little buggers. Sure enough, at one point in time, they let the magic smoke out as I could see a tiny (really tiny) crack on top of each. *poof*

Now the fun part. I called ICOM support and to my surprise they were willing to sell me parts! Cool. They have everything... except D9 and D10 which are 1SS375-TL-E Diodes. Sigh.

After much google-fu and a tired index finger from all the clicking, I finally found a goldmine of parts; <http://www.bdent.com>.

For \$1.50 each, I ordered four. Only ones on the planet as far as I can tell. Less than a week later and they were in my hands. Less than a day after that, they were soldered on the Filter board.

After I hooked up my trusty and proven peak-in-the-coax tool, I set the rig to 10W and pressed the PTT. YES! 10W steady into the dummy load. Modulation looked great and no power fluctuation. Fixed!

After putting it all back together, I was on the air! I think my first contact was a check-in on the Noon Time Net @ 7283.50. 30W to Reno. It’s been running great ever since. Not bad for a \$10.00 repair.

Now that pesky external wattmeter. AM, FM, CW all display the actual power output. SSB is averaging. I need a peek detector for SSB. I think I can fix that... maybe. See you next month. **73, Dan, KG7DAB**

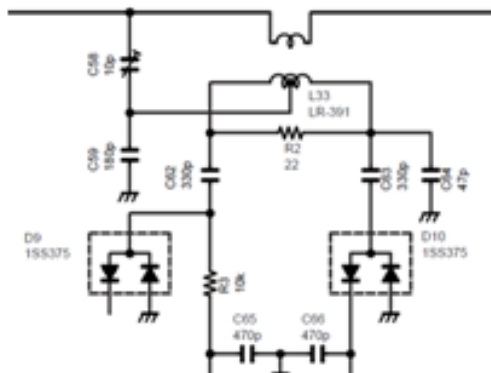

The Sunday 220 Net continues to operate on 224.120Mhz at 3:00 pm every week. We have regular participants and new check-ins every week. The group continues to grow.

We’re attempting to make it a mix between a social & technical net. On the Facebook page ‘220 Enthusiasts’ we’re getting inquiries from all over the country if we have IRLP, EchoLink, or some other type of computer aided systems to join the net.

March 2018

What we can use from you is some help in setting up systems that will do this. IRLP, EchoLink and the like will need a dedicated PC and radio *Around the Shack*. If you know a better way, that's great! Please share it.

Send me an email at KC7FBN@ARRL.NET and let's see what can be done for the 220 Net and possibly the club as a whole. **73 -Rob KC7FBN**

This Around The Shack had two by-lines this month. We're finding our groove.

Are you a closet Elmer and just don't know it? Do cool electronic and ham radio stuff *Around The Shack*? If so, please share it! Others really need this, they just don't know it until you write about it.

Send me an email at kg7dab@arrl.net with an attached MS Word document containing your article. Got Pics? Paste them in. Then, I will format the articles you send me and hand them over to our Relay editor, Michael, to post into the Newsletter.

Let's see how many Bylines we can get in next month's [Around The Shack](#).

Membership Committee Report

submitted by Rita, KD7CNU

The Membership Committee has begun working on the Awards Banquet. While we won't have the entertainment we had last year, we are hoping this year will be just as entertaining. We will once again have our banquet at the Burien Elks Lodge. Date and time to be determined. We are planning on Saturday, April 7, subject to Lodge availability.

This year's theme will be Carnival. We are having fun planning this and hoping you'll make plans to join us. We will have more information for you next month. We will be keeping the cost of the dinner at \$15.00 per person. There will be no host bar service.

We will have our next meeting, Saturday, March 17th following the general meeting at the Renton Library at noon. Please join us as fresh ideas are always welcome.

Tough Month

submitted by Michael, N7WA

It's been a tough Fall and Winter. No, nothing to do with Fleamarkets. Instead, We have seen a large number of Silent Key announcements for former and current Mike & Key members. These are people I was proud to call friends or still did call friends. Some are going to be listed below.

K7LED Relay

As we pass through life we meet many people. Some don't make much of an impression. Some make a big impression, whether good, bad, or mixed. It does make life interesting. I have to say, this Club tends to attract "characters". Unique individuals. I don't think that is a bad thing. Their passing makes life sad, but as I read the announcements below, I do have memories that make me smile.

Silent Key - Gene Jacobson WA7TAI

submitted by Michelle WB7AYU

Hi Members, especially old timers, I just returned from Camano Island. where I learned at one of my old breakfast haunts this morning that Gene Jacobson WA7TAI had passed away on 1/12/18. Gene joined the Club in 1974 and remained very active until the 1990's.

After a career at Puget Power, he moved from Kirkland to Camano and built a nice home on a 5 acre spread. Selected high for a ham location, he along with W7GPW put together quite an impressive antenna farm. He was very active on UHF and packet.

Around 2005, Gene decided to dispose of all the things accumulated and moved to a retirement home in Stanwood. We had lots of adventures together; going to Hawaii for 2 weeks in 1984 and operating HF from a new location every night. Going to Dayton 3 times. Flying with W7MCU (SK) to Canada for fishing and to many Hamfests over the years.

On May 18, 1980 we were headed to the Yakima Hamfest and got caught up in the Mt. St. Helens eruption and spent 3 days in Thorp WA. running welfare traffic from the High School Gym.

Throughout the 70's he was involved in public service communications and attended many of our Field Days at Marrowstone Island. He will be missed, he was a good friend.

Silent Key - Mike Eakins K7OV / W7DME

David Michael Eakins of Renton, WA passed away at the age of 69 on February 13, 2018 at the Kline Galland Home in Seattle, WA. He was born on June 28, 1948 in Des Moines, Iowa. David met his wife Mary at a picnic in Arizona and together they celebrated their 49th Wedding anniversary in October 2017. They settled in Renton and raised 3 children.

David was a merchant marine, working as a radio operator. He had such a passion for his work that he also

was a Ham radio (Amateur) operator during his spare time and always participated during the 3-day annual field event where the focus is to try contacting as many people as possible from different countries. Mike held a number of Board positions and was President of the Club in 2007



From Rowland W7DNE: *With sadness I would like to inform that Mike Eakins passed away yesterday. For those of you that did not know him he was the generous soul from the SeaTac Repeater Group that has let us use the 55 repeater for our ARC business and nets. From what I understand that will not change. Mike's radio knowledge was very deep. I use to say he had forgotten more than I will ever know. He taught me a great deal in the radio world and I will always appreciate that fact. Sometimes Mike could be a little grumpy but that was usually due to med issues during his struggle with diabetes. Mike lost that battle yesterday and he will be greatly missed.Mike*

Silent Key - Jim Etwiler KD7BAT
submitted by Michael, N7WA

This one hits me particularly hard and I am not afraid to say this is really difficult to write. Jim was a good friend personally and to the Club. Jim has been a member of the Club since March 1999 and his impact has been considerable since he joined.



He was our Treasurer for several years. Even when not on the Board, we was a fixture at many Board meetings. He was our Webmaster. He was an unsung hero of the Fleamarket out at registration plus he would show up wherever something needed doing. Field Day was no different. He upgraded to Extra so he could do VE Exams. He was one of our representatives to the the Salvation

Army. He was there for every Postal Food Drive and organized our Christmas Bell Ringing efforts. He worked with King County Search and Rescue. He worked Seafair.



He was active in non-Ham radio activities as well. He was a well-deserved Pop Brown Award winner in 2012. The Membership Committee made him the inaugural "Handy Ham " Award winner in 2015.

Jim will be missed greatly.

Silent Key - Jim Etwiler, KD7BAT
From David Smith, KB7PSN, Club President

Recently, the Club lost a member, Jim Etwiler, KD7BAT, a soft spoken individual who seemed to enjoy helping out. Jim was a long-timer in the Club and helped out in many different ways.

In recent years, Jim was very helpful during Field Day exercise over in Ft Flagler. In the morning, he would help cook breakfast at Camp Wilson. He would ensure that there was enough morning coffee to go around – when the pot was empty, all of a sudden there was more brewing. Someone would ensure that there was ample the water supply up on The Bluff, collecting ice from the Camp Wilson ice machine, as needed. He would even stick around to help clean up (mopping, sweeping, taking out the garbage, etc.) after everyone went home.

Many times, Jim would volunteer to tow one of the tower trailers from Skyway TV up to Fort Flagler and back again, across the Tacoma Narrows Bridge. Nice to see the familiar tower and equipment over there during set-up. When something was needed on The Bluff – Jim always seemed to have the item in his truck or knew how to get one.

During Flea Market, Jim was frequently seen helping out, where needed. Even supplying one of the cash boxes for the Country Store. As Club Treasurer a couple of years ago, he would ensure that all money was accounted for (serving as Treasurer for a while, I can appreciate what he

March 2018

did) -- there is a lot of behind the scenes work done to ensure everything flows correctly.

For the longest time, Jim was the Webmaster for our Club web site, <http://www.mikeandkey.org> with me as the back-up webmaster. He helped the current Web Committee get its new "look and feel" up and running by creating an initial version of the site map.

Jim was also the Club interface to the Salvation Army Captain and crew. In past years, he helped recruit help for both the May Postal Food Drive at the Renton Rotary and the even managed to get a crew together to work the "red Kettles" during the Christmas holiday season.

Back in 2015, the Club awarded him the first "Helping Hams Award," an award given by the Membership Committee at the Annual Awards Banquet (in 2016, this award was given to Peter Glaskowsky, the last recipient).

At the March 2018 Board Meeting, the name of this award was changed to the "Jim Etwiler Helping Hams Award." The Club looks forward to finding a recipient this year at this year's Awards Banquet – someone who has a similar passion for helping out.

So long to our friend and colleague, Jim.

Services for Chuck Graff, K7CHV

Chuck's (K7CHV) Memorial Service will be held on April 4th (his birthday) from 1-3 pm at Calvary Chapel South, 1340 W. Smith Street in Kent. Please pass the word. Call me if you have any questions (Lorie @ 425-392-5846.)

Amateur's Code *submitted by Rob, KC7FBN*

I've been reading some posts that tend to be 'anti amateur (and other radio)' use. I'd like to remind my fellow radio operators that The Amateur's Code written in 1928 by Paul Segal W9EEA is:

1. CONSIDERATE: never knowingly operates in such a way as to lessen the pleasure of others.
2. LOYAL: offers loyalty, encouragement and support to other amateurs, local clubs and the ARRL, through which Amateur Radio in the US is represented nationally and internationally.
3. PROGRESSIVE: with knowledge abreast of science, a well-built and efficient station and operators above reproach.

K7LED Relay

4. FRIENDLY: slow and patient operating when requested; friendly advice and counsel to the beginner; kindly assistance, cooperation and consideration for the interests of others. These are the hallmarks of the amateur spirit.

5. BALANCED: radio is an avocation, never interfering with duties owned to family, job, school or community.

6. PATRIOTIC: station and skill always ready for service to country and community.

Just my thoughts, KC7FBN & WRAJ462. (I'm legally licensed in both.) The reason I began in 2 way radio, CB, is to assist my neighbors, community and nation. As a VOLUNTEER Emcom radio operator I'm not at all concerned about what bands, frequencies or modes you use with consideration of: 1. The bands & frequencies are within your license privileges, 2. Legal, 3. Best practices & band plan, 4. The bands, modes etc are used to the best of your ability, 5. In keeping w/parts 95 & 97.

My fellow Emcom radio operators please accept my sincere apology if my views are not politically correct. Be well & safe out there!

The only purpose for this post is to promote inclusion of ALL individuals who wish to serve the needs of others through radio.

Comm Academy - 2018

Registration for the April 14th and 15th Comm Academy is now open. Location is South Seattle Community College, just North of White Center

[Registration / further info](#)

or see your copy of the green Public Service Pamphlet just released at the Fleamarket.

ARRL Request Tech Privileges Expansion *from the ARRL Web Site*

ARRL has asked the FCC to expand HF privileges for Technician licensees to include limited phone privileges on 75, 40, and 15 meters, plus RTTY and digital mode privileges on 80, 40, 15, and 10 meters. The FCC has not yet invited public comment on the proposals.

Specifically, ARRL proposes to provide Technician licensees, present and future, with phone privileges at 3.900 to 4.000 MHz, 7.225 to 7.300 MHz, and 21.350 to

21.450 MHz, plus RTTY and digital privileges in current Technician allocations on 80, 40, 15, and 10 meters. The ARRL petition points out the explosion in popularity of various digital modes over the past 2 decades.

Under the ARRL plan, the maximum HF power level for Technician operators would remain at 200 W PEP. The few remaining Novice licensees would gain no new privileges under the League's proposal.

ARRL's petition points to the need for compelling incentives not only to become a radio amateur in the first place, but then to upgrade and further develop skills. Demographic and technological changes call for a "periodic rebalancing" between those two objectives, the League maintains.

Now numbering some 378,000, Technician licensees comprise more than half of the US Amateur Radio population. ARRL said that after 17 years of experience with the current Technician license as the gateway to

Amateur Radio, it's urgent to make it more attractive to newcomers, in part to improve upon science, technology, engineering, and mathematics (STEM) education "that inescapably accompanies a healthy, growing Amateur Radio Service," ARRL asserted.

The Entry-Level License Committee determined that the current Technician class question pool already covers far more material than necessary for an entry-level exam to validate expanded privileges. ARRL told the FCC that it would continue to refine examination preparation and training materials aimed at STEM topics, increase outreach and recruitment, work with Amateur Radio clubs, and encourage educational institutions to utilize Amateur Radio in STEM and other experiential learning programs.

Mike & Key ARC General Meeting Saturday, February 17th, 2018 at 10:00 am Salvation Army Building, Renton, WA

Opening:

The meeting was called to order at 10:00 am by the President, Dave Smith KB7PSN.

The Pledge of Allegiance was recited. Members and guests were introduced: "What will be your Flea Market role this year?"

Announcements:

The Mike & Key ARC is affiliated with the ARRL, which members are encouraged to join. Everyone - including visitors - should sign the rosters. Visitors are reminded not to vote on membership matters.

Officer Reports:

President - Dave Smith KB7PSN: Three Silent Keys were reported: Charles Graff K7CHV, Gene Jacobson WA7TAI, and

Mike Eakins W7DME. Memories were shared, and a moment of silence was held.

Secretary - Phillip Pia K7PIA: Nothing to report.

Treasurer - Jim Kiniry KE7JIM: If you need to pay your dues, come see me after the meeting.

Activity Manager - Jim Monson K7JGM: There is some good stuff for the raffle today. A Flea Market primer will be today's program.

Vice President - David Yarbrough WA7DY: A quorum is present.

- Minutes: Peter Glaskowsky K4PNG moved to accept the minutes as published in the Relay; Ivy Nelson-Groves WA7IVY seconded the motion. The motion passed.

- New Membership: Terry Hissong KG7PO, Daryl Wheeler N7DFW

- Recognition: Jim Monson K7JGM and James Wraalstad WQ7H for 5 years of membership.

Chairman of the Board - Tim Kane K7ANE: The second round of nominations for the March elections is today.

Radio Officer - Hal Goodell N7NW: The repeaters are working great. There is a net at 3 pm on Sundays on the Club's 220 repeater.

Editor Reports:

Relay Editor - Mike Dinkelman N7WA: It was a great issue last month. Be sure to send in your articles and pictures; contribute to your club's newsletter!

Website Committee - Dan KG7DAB: The new [website](#) is doing great. The latest content has been uploaded.

- Tim Kane K7ANE: We will be updating our front page mission statement to help convince the IRS of our non-profit status for our 501(c)(3) application.

Committee Reports:

Membership - Kathy KB7QMO: Tickets for the [Awards Banquet](#) on April 7th at the Burien Elks Club are available for \$15. This year's Awards Banquet theme will be a carnival (with games and

everything), and the dinner will be served buffet-style (choice of prime rib, chicken, or vegetarian option, with fingerling potatoes and veggies, and optional dessert for \$4 extra). The next committee meeting will be at the Renton Library after the General Meeting.

Facilities and Publicity - Steve Cook KD7IQL (liaison): Nothing to report.

Education and Training - Daniel Stevens KL7WM: "There is a Technician Class on March 17 and 24 in Federal Way, a Technician class and a General class on April 21 and 28 in Ballard, and a Technician class on May 12 and 19 in Issaquah. Comm Academy is on April 14/15, and Sea-Pac is on the first weekend of June. These are great training events." Be sure to check out the Education page on the website for the latest info.

- KD7WNV: A 2 month long, weekly Technician licensing course will be taking place on Monday nights at 7-9 pm in Kenmore.

- K4PNG: A live video stream of the (currently sold-out) [MicroHams Digital Conference](#) will be available.

March 2018

K7LED Relay

Public Service - Robert Grinnell KD7WNV: The layout for the booklet has been completed, the cover will be lime green in

color, and the content has been updated for this year. March public service events include the St Patrick's Day parade, the Daffodil Parade, and the MS walks.

Technical and Special Interest - Steve Marth WB7AAV (liaison): The Technical Net continues on Wednesday evenings at 7:30pm on the Club 2m repeater.

VE Exams - Scott Robinson AG7T: 19 examinees were present for the January session, resulting in ten Technician, four General, and three Amateur Extra class licensees. The next VE Exam session will be taking place in here at 12:30 pm.

Flea Market - Hal Goodell N7NW/Mike Dinkelman N7WA: The program will be about Flea Market. Volunteer sign ups are available to all (not just members and hams), and we still need a couple of people to help set up the phone system on Thursday.

Field Day - Ivy Nelson-Groves WA7IVY: It will be taking place on the June 23rd/24th weekend.

Old Business:

- Nominations: The second round of nominations for the March elections was held. After today's nominations, the current nominees are as follows: for President, David Smith KB7PSN; for Vice President, Phillip Pia K7PIA, David Yarbrough WA7DY,

and James Wraalstad WQ7H; for Secretary, David Yarbrough WA7DY; for Treasurer, Jim Kiniry KE7JIM; for Activities Manager, no one; and for Trustee positions 2/4, Phillip Pia K7PIA, Ivy Nelson-Groves WA7IVY, Jim Monson K7JGM, and James Wraalstad WQ7H.

New Business: None heard.

Alligator Award: Rob KC7FBN timed out the 220 repeater during the January 27th 220 MHz net, and is now the proud owner of a box of alligators!

Good of the Order:

- Ryan Heinig KE4TNN: He is currently looking for a 30 amp power supply for a Yaesu 857D HF transceiver that he bought months ago; if anybody is willing to sell or lend, please let him know after the meeting.

- Michael Hansen KG7MX: Thanks to Phillip K7PIA for doing a great job as Secretary these past two years.

Closing:

The next Mike & Key General Membership meeting is on the third Saturday of the month - March 17th at 10:00 am at the Salvation Army Building in Renton.

Sam Sullivan N7RHE made a motion to close the meeting and was seconded by Monica Cook; the motion passed. The meeting was adjourned at 11:14 am.

Guests: 6 Members: 62 ARRL Members: 55
Attested: Phillip E. Pia, K7PIA - Secretary.

Mike and Key ARC Board Meeting Tuesday, March 6th, 2018 at 7:15 pm Salvation Army Building, Renton, WA

Officers Present:

President Dave Smith KB7PSN, Vice President David Yarbrough WA7DY, Secretary Phillip Pia K7PIA, Treasurer Jim Kiniry KE7JIM, Activities Manager Jim Monson K7JGM, Radio Officer Hal Goodell N7NW

Trustees Present:

No. 1 Steve Cook KD7IQL, No. 2 Steve Marth WB7AAV, No. 3 Tim Kane K7ANE, No. 4 Tom Helm WT7S (Absent: No. 5 Robin Carter WA7BRI)

Visitors:

Michael Hansen KG7MX, Ivy Nelson-Groves WA7IVY, Daniel Stevens KL7WM, Michelle Cross WB7AYU

Opening:

The Chairman of the Board Tim Kane K7ANE called the meeting to order at 7:15 pm, with a quorum being present. Jim Kiniry KE7JIM moved to approve the minutes as published, with Jim Monson K7JGM seconding; the motion passed.

Officer Reports:

Chairman of the Board - Tim Kane K7ANE: Nothing to report.

President - Dave Smith KB7PSN: Jim Etwiler KD7BAT recently became a Silent Key; the Helping Hands award will be renamed in honor of him. The Board approved the motion to do so. A

moment of silence was held, and there was a recognition of his numerous duties of service to the Club over the years; he will be greatly missed.

Vice President - David Yarbrough WA7DY: Three membership applications were received this month: Douglas Reynolds KE7YVA, Ryan Heinig KE4TNN, and Scott Gilyeat KC7SAG. The Board approved the applications.

Secretary - Phillip Pia K7PIA: Nothing to report.

Treasurer - Jim Kiniry KE7JIM: We are ready to go for the Flea Market this weekend.

Activities Manager - Jim Monson K7JGM: The annual Club board elections will be taking place at the next General Meeting. There will be good stuff for the next Raffle, as usual.

Radio Officer - Hal Goodell N7NW: The repeaters are working fine. There is still lots of snow at the repeater site. When we are able to go up there, we will take a look at the 2m antenna.

Editor Reports:

Relay Editor - Mike Dinkelman N7WA: Content is due by Friday evening (or Sunday morning if you have any Flea Market content to contribute).

Website Committee: Dave Smith KB7PSN mentioned that Dan Aalberg KG7DAB needs some direction regarding the addition of Silent Keys to the website. It was suggested that if a Silent Key was ever a member (current or past), he/she should be added to the list on the website; also, that Dan should receive a copy of the roster via email (which includes the list of Silent Keys to date).

Committee Reports:

Education & Training - Robin Carter WA7BRI: Not present.

- Daniel Stevens KL7WM: From his latest email report - "There is a Technician Class on March 17 and 24 in Federal Way, a Technician class and a General class on April 21/28 in Ballard, and a Technician class on May 12 and 19 in Issaquah. Comm Academy is on April 14/15, and Sea-Pac is on the first weekend of June. These are great training events."

Membership – Tom Helm WT7S: We have secured the facility and paid the \$200 deposit for the Banquet at the Burien Elks Club; it will be on April 7th, the dinner will be a buffet, and the theme will be a carnival (casual). The costs were discussed.

Technical – Steve Marth WB7AAV: The Technical Net continues on Wednesday evenings at 7:30pm on the Club 2m repeater.

Public Service - Tim Kane K7ANE: The booklet is ready for distribution at the upcoming Flea Market.

Facilities – Steve Cook KD7IQL: There has been no success so far in getting in contact with the Salvation Army, in regards to the

rental agreement. This will be pursued further after the Flea Market.

Field Day - Ivy WA7IVY: We are in the process of getting everything ready with the park. Currently, there are three drone permit requests. The next trailer work party will be on May 6th. An inventory of the trailers will be done at Field Day.

Flea Market - Hal Goodell N7NW: Pre-setup will take place on Thursday, the major setup is on Friday, and the event is on Saturday.

- Tim Kane K7ANE: Overhead video of the event (with drones) is being considered.

Old Business:

- David WA7DY: A replacement for our Yahoo Groups email lists - Groups.io - is being explored and tested; a follow-up report will be given at the next Board Meeting for transition consideration.

- Elections Discussion: The Activities Manager position (which currently has no nominations) has always been a tough sell come election time; solutions were discussed (including possibly offloading the Raffle responsibility to another person).

New Business: None heard.

Good of the Order:

- Michelle WB7AYU: There are still some volunteer positions open for the Flea Market.

Closing:

The next Board Meeting will be on Tuesday, April 3rd at 7:15 pm at the Salvation Army Building in Renton.

There being no further business, the Chairman adjourned the meeting at 8:42 pm.

Attested: Phillip E. Pia, K7PIA - Secretary.

New NW Division Scholarships from the ARRL Web Site

If you have kids or grandkids headed for college that you've managed to license, the following may be of interest.

The ARRL Foundation has announced a new scholarship, the Joel R. Miller (W7PDX) and Martha C. Miller STEM Scholarship. Endowed through the generosity of Joel R. Miller, W7PDX, and Martha C. Miller, this scholarship is intended to supplement the educational expenses of an Amateur Radio operator pursuing higher education. The ARRL Foundation will administer the scholarship, which is \$1,000 annually to fund the costs of tuition, books, fees, and other educational expenses. The first scholarship from this endowment will be awarded in 2019.

Applicants must be a US citizen, without regard to gender, race, national origin, or handicap status, residing in the ARRL Northwestern Division (Alaska, Idaho, Montana, Oregon, and Washington). Those applying must be pursuing an associate's or higher degree in the fields of science, technology, engineering, or mathematics (STEM) at an accredited institution of higher education and have a 3.0 or higher grade point average at a high school or an accredited institution of higher education for the academic year immediately prior to the application period.

Ramblings from the Fleamarket

submitted by Michael, N7WA

Another great Fleamarket event under our belt. This was number 37. In no particular order....

All the customers I chatted with seemed happy with the business they did. The Country Store had a lot of stuff that seemed to go away. I know the two estates I was handling were severely reduced and all that free stuff clogging my garage is gone. (I only put that out AFTER we open the doors to the public.)

We found out the fairgrounds moved some walls upstairs. That allowed us to add 6 tables and make some people on our waiting list happy. Alas, a number of people canceled at the last minute so we ended up with some empty tables but officially, it was still a sell-out.

Hope everybody got plenty to eat at hospitality. Michelle, Pat, and Iscel did a good job setting up. If I had known the smoked salmon was going to go so fast, I wouldn't have opened it so early. N7STR said he needed some

March 2018

bagels and cream cheese cream... until he tried it... didn't need bagels or cream cheese after all.

We had a lot of new faces out at registration. That, combined with trying to sell the added tables provided some stress out on the runway but they came through fine in the end. Jim KD7BAT was certainly missed. Next year, they are all going to be seasoned veterans. We are going to need to investigate alternate communications for registration. The FRS radios that have worked well in the past were obliterated by local pulsing interference. Maybe back to 2M or 220MHz.

Load in at the dock was a non-event. That's about the best compliment you can give. There were some issues at load out with customers standing or walking in the way with pallets flying by. We may have a new job for security next year. There was also some chatting at the Chinese Dinner about a couple possible tweaks to the table call-in process.

It was noted that we must remember to follow the IDing rules when using our handi-talkies. It was getting a bit lax in some situations. Granted, I doubt if the FCC is listening but our customers may. Best to follow the rules.

No observations about the PA. I think Ivy and her crew have that one nailed. Anybody hear about the VE's. How'd they do?

George and Dick seemed to manage the ticket booth without too much issue. I did get a call from an irate customer. He came down with nothing smaller than \$100 bills and he arrived after 10AM, by which time we had closed down the credit card sales. So next year, I think we put the \$20 bill restriction on the flyer and maybe we need to talk more about the credit card sales and training another person to do them.

We had issues at Ticket Taking. Mostly due to last minute cancellations due to illness. Hal and I talked about needing a dedicated person to manage the area. Might seem too trivial but he and I spent a lot of time out there. My thanks to Marshall, Phil, David, Tom, and Annie for stepping in when asked to fill in. This area is perennially tough to find workers. The past weekend wasn't bad weather-wise but it can be cold and wet. We are open to ideas to make it better.

I watched one gentleman get hand-stamped on the forehead. ??

Not too early to make your plans now, next year is March 8th and 9th.

K7LED Relay

I did learn two devastating pieces of news at the event. Two of our members will be moving on to other opportunities that preclude their participation in the future. In other words, they are moving away. I won't "out" them. I leave those announcements to them, but I will miss them both.

I think we are going to have a lot of video of this event. David WA7DY sent up his drone during early load in. Ric, K7RIC was walking around with a GoPro on a stick, and James WQ7H sent me some video I have yet to review. We'll get those and pictures all linked up on the Web page soon but you can start here with David's drone shots.

Here is a playlist that will play them all:

<https://www.youtube.com/playlist?list=PLU72YmmAln2bzrjoFeku6h0idR3YzyWXe>

And links to the individual videos:

https://youtu.be/FRt_WLydQZg
https://youtu.be/dSz_V1IPRsE
https://youtu.be/1zb1_w3XIMw
<https://youtu.be/cdhBk0P68b4>
<https://youtu.be/PXAqS1SdgDU>
https://youtu.be/WrdOll_nvDA

I am sure I missed people and events worth mentioning. My thanks to you all for making this event a success.

[Pacific Northwest Hamfairs & Events](#)

March 24. MicroHams Digital Conference, Redmond, WA. [**Conference is sold out**]
<http://www.microhams.com/mhdc/>

April 7. Yakima Hamfest. Yakima, Washington.
<http://yakimaamateurradioclub.com/yakima-hamfest/>

April 7. Swap Meet & Emergency Communications Equipment Exhibition. Richmond, BC. https://secure.eton.ca/rac/events/detail.php?event_ID=1926

April 14 & 15. Communications Academy. South Seattle Community College, Seattle, WA
<http://commacademy.org/>

April 20-22. Idaho State Convention. Boise, ID.
<http://www.idahostateconvention.com/>

May 5. Electronics, Ham Radio and Experimenters Swap Meet, Kennewick, WA. Contact: DANCAR68@AOL.COM

March 2018

K7LED Relay

2018 Fleamarket

[Sorry if you missed out. Click here for more pictures](#)
(or add your own if you have a gmail account)



| March / April 2018 | | | | | | |
|---|---|-----------|--|-----------|-----------|--|
| Sunday | Monday | Tuesday | Wednesday | Thursday | Friday | Saturday |
| 11 (March) 220 Repeater Net 3:00pm 224.120 PL103.5 | 12 | 13 | 14 Mike & Key Technical Net 7:30pm 146.82 | 15 | 16 | 17 10:00-M&K Club Mtg [Salvation Army- Renton] 12:30- Ham Radio Exams Contact: Scott—ag7t@arrl.net Elections! |
| 18 220 Repeater Net 3:00pm 224.120 PL103.5 | 19 | 20 | 21 Mike & Key Technical Net 7:30pm 146.82 | 22 | 23 | 24 MicroHams Digital Conference CQ WW WPX Contest, SSB |
| 25 220 Repeater Net 3:00pm 224.120 PL103.5 CQ WW WPX Contest, SSB | 26 | 27 | 28 Mike & Key Technical Net 7:30pm 146.82 | 29 | 30 | 31 |
| 1 (April) 220 Repeater Net 3:00pm 224.120 PL103.5 | 2 Board Meeting 7:15 PM Salvation Army | 3 | 4 Mike & Key Technical Net 7:30pm 146.82 | 5 | 6 | 7 M&K Banquet Burien Elks Yakima Hamfest |
| 8 220 Repeater Net 3:00pm 224.120 PL103.5 | 9 | 10 | 11 Mike & Key Technical Net 7:30pm 146.82 | 12 | 13 | 14 Comm Academy |
| 15 220 Repeater Net 3:00pm 224.120 PL103.5 Comm Academy | 16 | 17 | 18 Mike & Key Technical Net 7:30pm 146.82 | 19 | 20 | 21 10:00-M&K Club Mtg [Salvation Army- Renton] 12:30- Ham Radio Exams Contact: Scott—ag7t@arrl.net |